

SILOKING

Selfline



Feed mixing technology

Quality and reliability – worldwide

SILOKING Mayer Maschinenbau GmbH produces innovative feeding technology and distributes it in more than 50 countries all over the world. The owner-managed family company is based in Tittmoning in Bavaria. With more than 500 employees and latest production methods, agricultural machines “Made in Germany” are developed and manufactured with high quality standards.

simply | intelligent | feeding

All of SILOKING’s considerations refer to “simply | intelligent | feeding” – focusing on the requirements of the cow and the farmer, finding solutions and implementing them.

Thanks to our innovative products and intelligent solutions for modern feeding technology, we support future-oriented farms that think progressively and want to successfully develop sustainable management of their dairy farms.



Reliability

The series production as well as continuous quality and end controls ensure highest quality standard and efficient production, because serial production creates reliability. At SILOKING, the high level of vertical integration also involves comprehensive documentation and organization of spare parts supply.

Experience

With over 37,750 units in the market, SILOKING has wide experience in manufacturing reliable, durable and efficient products. Flexible assembly lines allow an up-to-date product mix and high production output.

SILOKING Canada Ltd.

Sales and service for
Canada and USA.

Putnam (CA)

SILOKING Elbe/Weser

Sales and service.

Gnarrenburg (DE)

SILOKING Slovakia

Production.

SILOKING Rus OOO

Sales and service for Russia.

Lipetsk (RU)

SILOKING Headquarters

Development, innovation and production
for all markets. Sales in Europe and
international markets.

Beijing (CN)

**SILOKING Agricultural
Machinery Beijing Co. Ltd.**

Sales and service for Chinese
market and Asia.

SILOKING do Brasil

Sales and service for
South America.

São José do Rio Preto (BR)

High quality 
MADE IN GERMANY

SILOKING

Security

Active sales worldwide through our own subsidiaries in Russia, Brazil, Canada and China as well as audited partners make SILOKING a competent producer. Thanks to experts and comprehensive spare parts inventory on site, purchasing a SILOKING is a reliable thing worldwide.

The driver is supported in comfort and precision by the increased use of assistance systems in all models. The automatic switching off of the mixing unit when reaching the end of the adjustable subsequent mixing time or the switching off of the mixing augers when the amount of feed per animal group has been completely discharged are only two examples.

These setting options, together with SILOKING Data included free of charge, a combination of programmable weighing system and Feeding Management Software, represent the state of the art in digitalised feeding and feeding management.

The optional SILOKING Telematics constantly and quickly transmits the machine data to the farm manager via app. Optimisation potential can therefore be identified and implemented at an early stage – day after day!



Compact 1612 13 m³ - 16 m³

For family farms and large farms, especially with confined and low-height buildings.

Page 32 - 33



Premium 2215 15 m³ - 22 m³

High volume utilisation for large farms and big loading height.

Page 34 - 35





System 300+ 2519 19 m³ - 27 m³

The robust and large-volume farm machine with increased ground clearance, for farms with 300 or more cows or fattening cattle.

Page 40 - 41



System 500+ 2519 19 m³ - 27 m³

Designed for farms with 500 and more animals, for increased logistic requirements as well as for several locations, feeding communities or agricultural contractors.

Page 42 - 43



System 1000+ 3225 25 m³ - 32 m³

For farms with 1,000 or more animals, designed for maximum payload and performance thanks to its 3-axle chassis.

Page 44 - 45



Selfline 4.0

Self-propelled vertical feed mixers from 13 m³ to 32 m³



NG
SelfLine
Premium 2215



SelfLine 4.0 in Detail



Mixing
Turbo auger, hopper

Page 8 - 11



SILONOX

as standard, on turbo augers, in the hopper

Page 12 - 13



Feed loading

High-performance milling head, conveying channel, knives

Page 14 - 15



Drive

Engine, hydraulics, radiator

Page 16 - 21



Comfort

Cab, control, driving

Page 22 - 25



SILOKING Data

Weighing, controlling, Feeding Management Software

Page 26 - 27



Compact / Premium

Chassis, models, feed discharge

Page 30 - 37



300+ / 500+ / 1000+

Chassis, models, feed discharge

Page 38 - 47

Accessories

Telematics, NIR System, straw chopper, DryScan®

Seite 28 - 29

Mixing matters

8

SILOKING





Hopper geometry and turbo auger are optimally matched

The size of the mixing hopper and the mixing auger is of great importance for a homogeneous mix. In order to achieve short mixing times and optimal preservation of the feed structure, every model of the SILOKING **SelfLine 4.0** has its own hopper that is carefully matched in shape, height and width. The size of the turbo auger is optimally adapted to the hopper dimensions.

Feed in perfect motion

The edged hopper slows down the feed in its circular movement and supports vertical mixing even with low filling levels. The conical hopper shape reduces the power requirement and therefore makes it possible to load and mix simultaneously – for time-saving work processes.

SILOKING 4-planet gearbox – where power is transmitted

The planetary gearbox has been developed exclusively and only for use in SILOKING Feed mixers. For the high performance expected from the feed mixer even under maximum load, this gearbox with 4 planets and optimal gear reduction levels has been designed with a maximum torque of 52,000 Nm. The gearbox is 100 % oil-lubricated, which equates to very easy maintenance.

Gentle mixing – quick unloading as standard

The speed of the turbo auger can be infinitely pre-programmed in 3 different modes:

- ▶ low speed (17 to 25 rpm) for gentle mixing
- ▶ medium speed (20 to 40 rpm) for quick cutting of long-fibred feed
- ▶ high speed (55 rpm) for complete residual emptying, e. g. when changing the ration (optional for Compact 13)

The different modes are selected by pushing a button, even during the mixing process.



Turbo auger for perfect mixing performance



Feed structure preservation and precision

Large mixing auger plus low speed equals gentle treatment of feed structure – that is the convincing equation in favour of the turbo auger. It rotates at a speed that can be described as gentle in spite of moving a high quantity of feed inside the mix with every rotation. The turbo auger is the result of years of experience and extensive testing by SILOKING.

Perfect mixing quality

The mixing augers are provided with an additional turbo flight as standard. This turbo flight ensures perfect mixing even of smaller ration quantities as well as quick and regular emptying of the mixing hopper.

Better cutting, faster mixing

The “pulling cut” is a special feature of the turbo auger’s XS knives. A better cutting effect (even for long-fibred feed components), less power requirement and better feed protection are proven advantages. The cutting angle of the XS knives can be adjusted in three stages and thereby easily adapted to individual requirements.

Optimal mixing of concentrates

The flat and adjustable scraping bars on the mixing auger and the turbo flight offer perfect collection of fine feed components – also from the hopper bottom. This ensures precise mixing even if concentrates are loaded first and allows for adding fine feed components any time. The wear-resistant scraping bar made of SILONOX is also an example of high stability, even under immense loads.

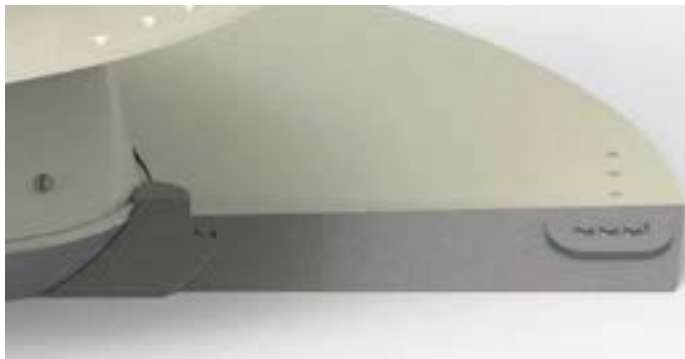

Adjustable scraping bar made of SILONOX.



Easy and safe cleaning thanks to the removable housing

Safety for people and animals thanks to the SILOKING heavy-duty magnet

The innovative SILOKING heavy-duty magnet provides reliable protection against metallic foreign objects in the feed. Thanks to its unique removable housing, separated metal parts can be easily and safely removed – without physical effort. Cleaning is ergonomic and injury-free, performed directly from the outside.

This solution was awarded a silver medal as part of the “Innovation Award EuroTier” 2024.

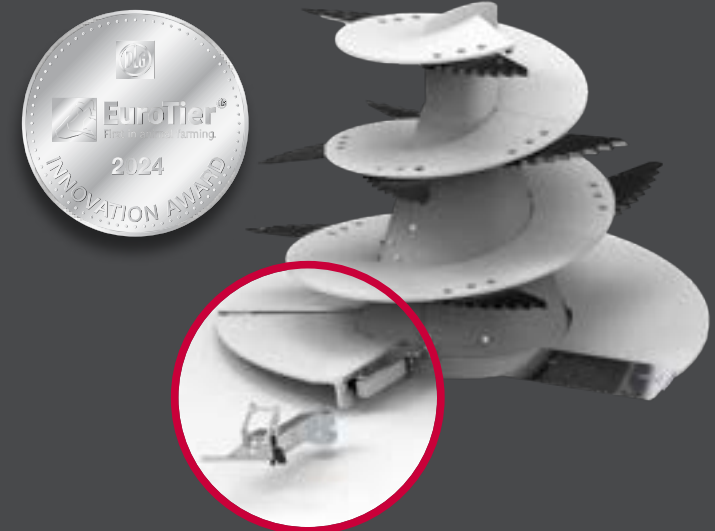

SILONOX for highest requirements

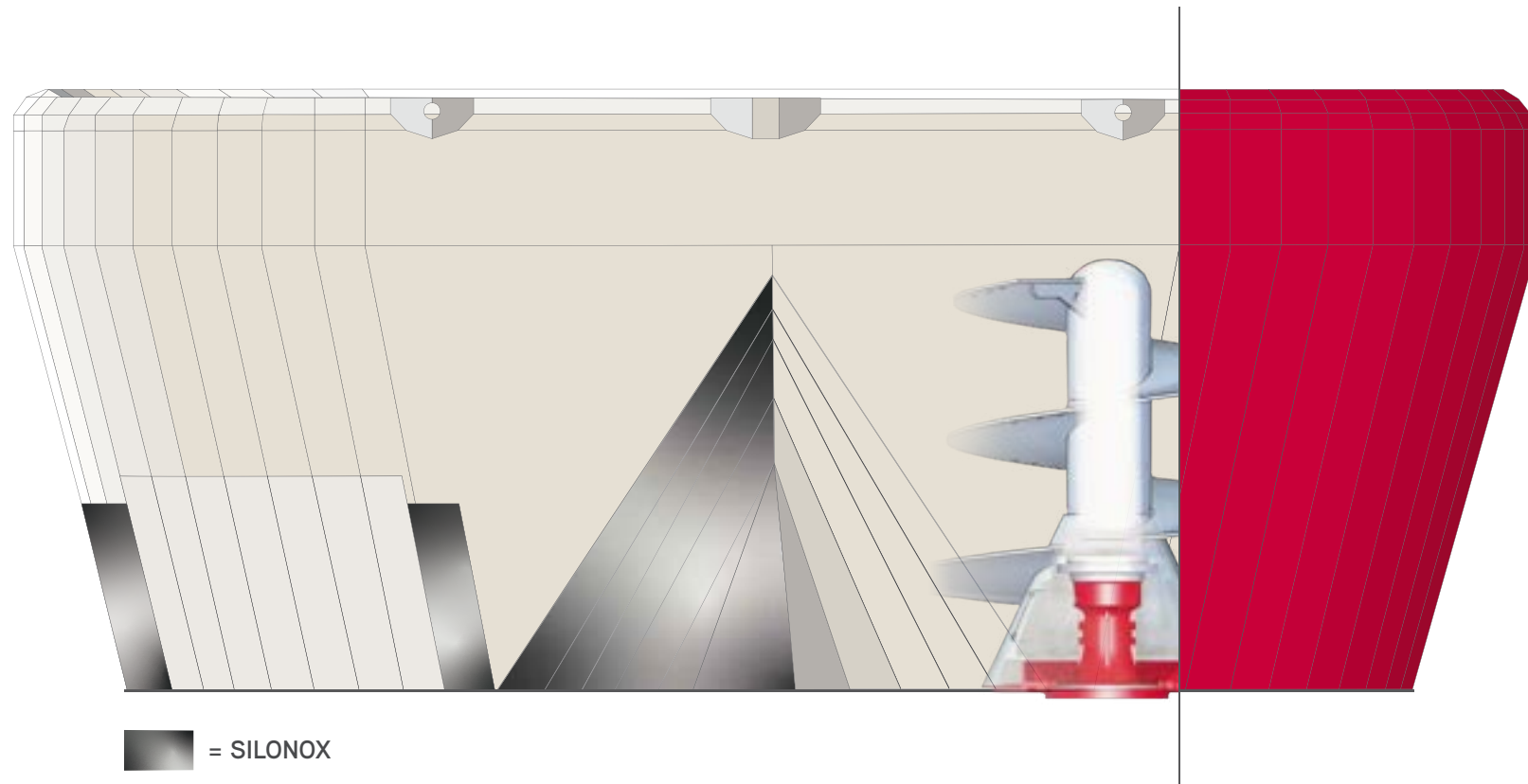

Standard hopper



completely made of SILONOX
(up to FlowPlus hopper ring)

increasing intensity of use 

◀ increasing intensity of use

15 mm standard (St-52)
up to 50 t (feed quantity/day)



SILONOX auger edge lining
15 mm standard (St-52)
+ 6 mm SILONOX
= 21 mm theoretical total thickness
from 50 t (feed quantity/day)



SILONOX auger
100 % made of SILONOX



SILONOX – Durability factor >3

SILONOX is a particularly hard-wearing stainless steel alloy, acid-resistant and at the same time extraordinarily wear-resistant.

SILONOX is highly resistant to corrosion, acid and chemical degradation. It also shows excellent resistance to mechanical wear resulting from the mixing process. Strong welds ensure permanent tightness and secure joins – no acid can penetrate.

Compared to the S355 (St-52) steel normally used in the mixing hopper, the durability factor is >3, i.e. it has at least 3 times longer service life.

SILONOX as standard

Those components of SILOKING Feed mixers that are subject to the highest degrees of frictional load are provided with wear-resistant plates made of SILONOX as standard. The wedge-shaped hopper recesses between the mixing augers as well as the areas on the sides of the discharge openings are provided with SILONOX Wear protection.

For highest requirements

The SILONOX Wear protection minimizes wear even with high throughput quantities. This allows for the service life of the machine to be greatly expanded without requiring any retrofits.

For processing a compact TMR, the SILONOX option is also recommended due to the acid protection, even with a significantly lower tonnage per day.



Exact loading

The mixing hopper and the loading unit are separated from each other, so only what gets into the hopper is weighed. By reversing the loading conveyor belt, components that have been collected in excess, such as concentrates, can be unloaded again.

Focus on feed structure

When it comes to efficient feed loading and simultaneous protection of the feed structure, SILOKING's motto is: no compromises. The 2 metre wide high-performance milling head is equipped with only 58 knives. Together with the centrally positioned, 700 mm wide conveying channel, it achieves high loading capacity with maximum preservation of the feed structure at the same time (see DLG test report).

The milling head can collect a wide variety of feed components precisely and cleanly from the ground. SILOKING even offers a milling head drum with a reduced number of knives for use in maize-based rations.

Designed for a long service life

The cranked knives on the milling head drum are coated with tungsten carbide on both sides and can be turned over when worn - for twice the service life! The milling head is made of SILONOX, the easily replaceable scraping bar of HARDOX®.

The ingenious design of the milling head drum and side covers prevents deposits of feed and ensures clog-free operation. To avoid torsion, the centrally positioned conveying channel is supported by one lifting cylinder on each side.



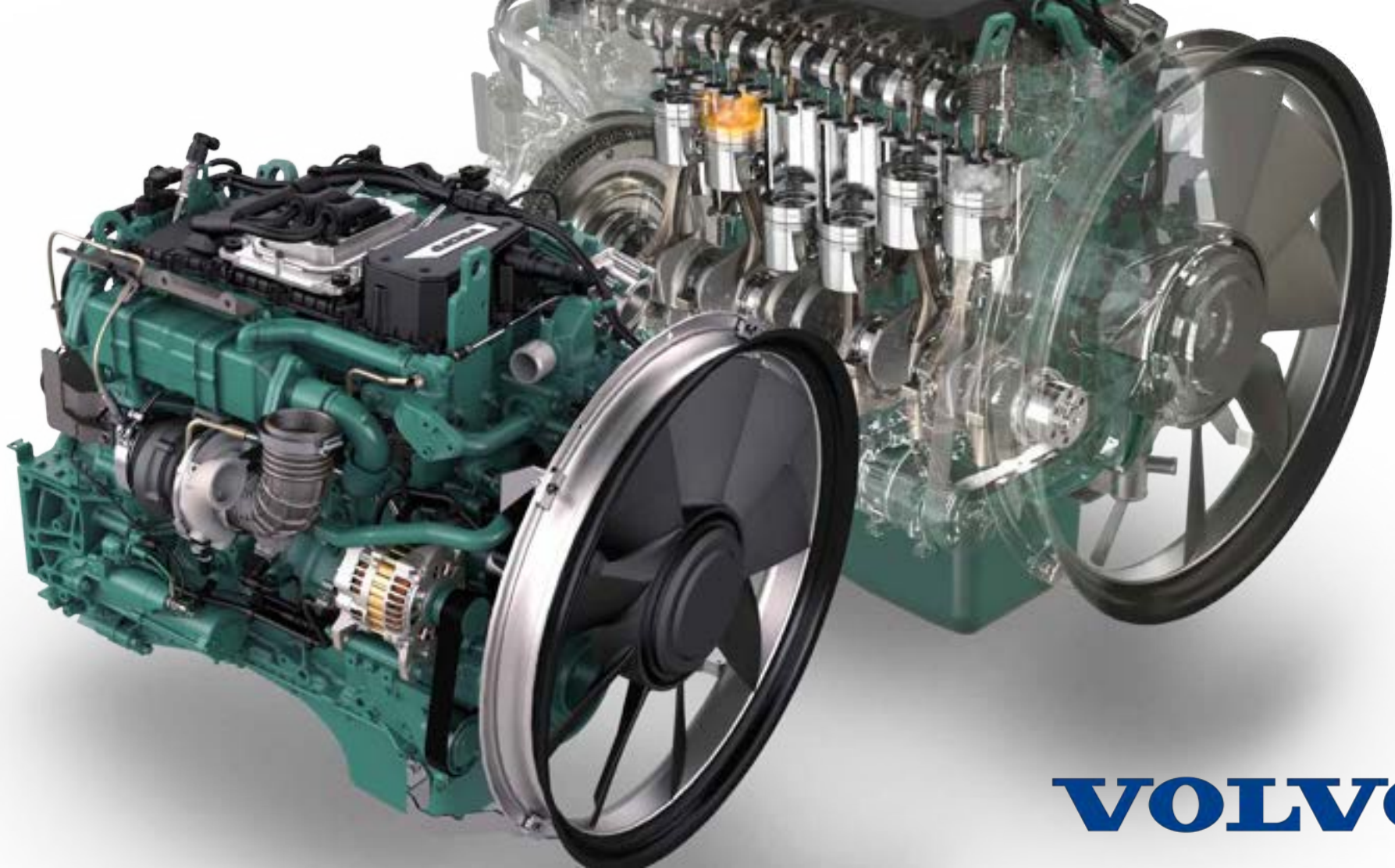

VOLVO

A strong heart

The SILOKING **SelfLine** 4.0 is equipped with a strong heart: The high-torque Volvo engine is not only extremely powerful and efficient – its extremely long maintenance intervals of 1,000 hours also make it uniquely economical.

The engine characteristics perfectly meet the requirements of the SILOKING **SelfLine**:

- ▶ The engine with very high torque at low speed is able to cope with even the highest peak loads when milling
- ▶ The long service life makes a reliable cost calculation of the entire machine possible
- ▶ The reduced vibration has an overall positive effect on the wear of the machine
- ▶ The low fuel consumption is an essential component of economic efficiency

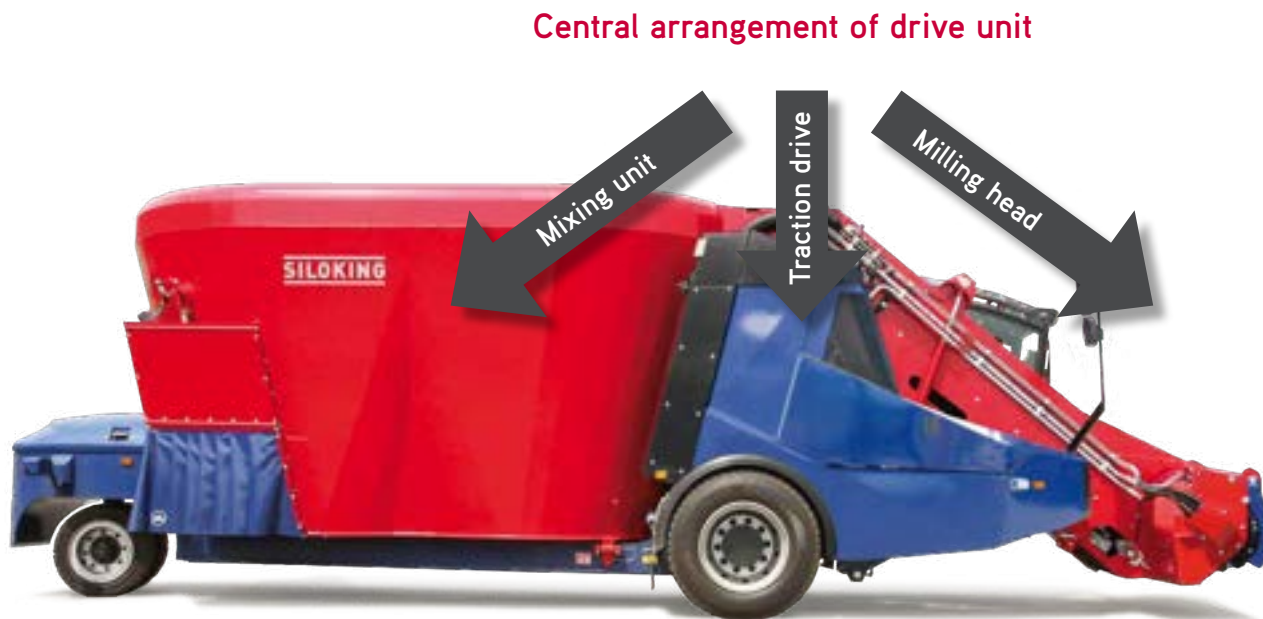

Central arrangement of drive unit

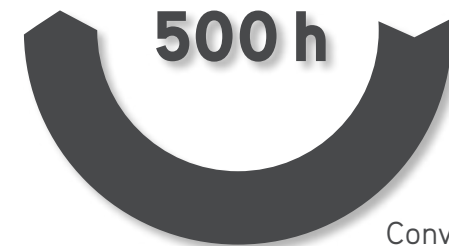

Conventional engine technology



SILOKING 4.0 engine technology

Central arrangement of drive unit

Short distances equal high efficiency. This simple formula describes the concept of the drive unit (engine and hydraulics) of the SILOKING **SelfLine** 4.0. The central arrangement of the drive unit with a short distance to the hydraulic consumers results in high efficiency and a minimised oil quantity.

Maintenance every 1,000 hours only

The engine oil only needs to be changed every 1,000 operating hours or once a year. As a result, the whole maintenance interval of the SILOKING **SelfLine** 4.0 could be changed to 1,000 hours. Compared to engines of similar power, this means 50 % less maintenance time and costs as well as significantly higher machine availability.

In combination with electronic monitoring of all engine functions, operating costs are minimised and operational safety maximised!



Refuel with HVO now

Sustainability as standard

The demands for climate-friendly agriculture are steadily increasing. SILOKING responds with a future-oriented solution: all self-propelled machines are delivered from the factory with 100% renewable HVO100 diesel. This actively supports farmers in achieving their climate goals and provides an easy way to significantly reduce CO₂ emissions in dairy farming.

What is HVO diesel?

HVO stands for “Hydrotreated Vegetable Oil” – a fuel produced from residual and waste materials such as used vegetable oils. Its properties are almost identical to fossil diesel, and it can be used directly without technical modifications. This means: no additional investments, full warranty, and an immediate switch to a sustainable alternative.



Up to 90% Less CO₂ emissions

Using HVO diesel reduces greenhouse gas emissions over the entire life cycle of the fuel by up to 90% compared to conventional diesel. SILOKING thus offers an economical and climate-friendly solution that preserves the value of your machines while protecting the environment.

Overview of benefits



excellent compatibility with all engine components



HVO can be blended with fossil diesel in any ratio



very good low-temperature resistance (down to at least - 20 °C)



no modification of the machine required



reduced AdBlue consumption by approximately 10 %



up to 90% lower greenhouse gas emissions (compared to fossil diesel)

Smooth hydraulics

Little oil – long intervals

All units of the SILOKING **Self**Line 4.0, such as the loading unit, mixing unit and drive unit are hydraulically driven. In spite of the high number of consumers, the sophisticated hydraulic system only requires 140 litres (Compact / Premium) or rather 250 litres (System 300+ / 500+ / 1000+) of hydraulic oil. Due to the central position of the drive unit (engine and hydraulic pumps), the distances to the consumers are short, which saves oil quantities.

Oil wears out mainly due to high temperatures, which can be avoided by good cooling. Thanks to the large-dimensional single-surface radiator of the SILOKING **Self**Line, less oil is needed in the circuit and at the same time the oil change intervals are considerably extended.

The hydraulic system of the SILOKING **Self**Line 4.0 is one of a series of highly efficient units that have one objective: maximum efficiency and economy.

Clean work – warm cold start

The service life of high-performance axial piston pumps depends largely on good maintenance as well as clean and tempered hydraulic oil! The technically sophisticated filter system with return line suction boost filter ensures 100 % filtering of the hydraulic oil and long service life of the pumps.

With the standard hydraulic oil pre-heating, the oil maintains its viscosity even in frosty temperatures. In combination with short lines to the consumers, the SILOKING **Self**Line therefore provides excellent cold-start behaviour.

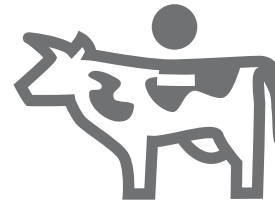

Triple saving SILOKING 4.0 hydraulic system



Oil quantity



1,000 h of maintenance interval



Standard oil and filters

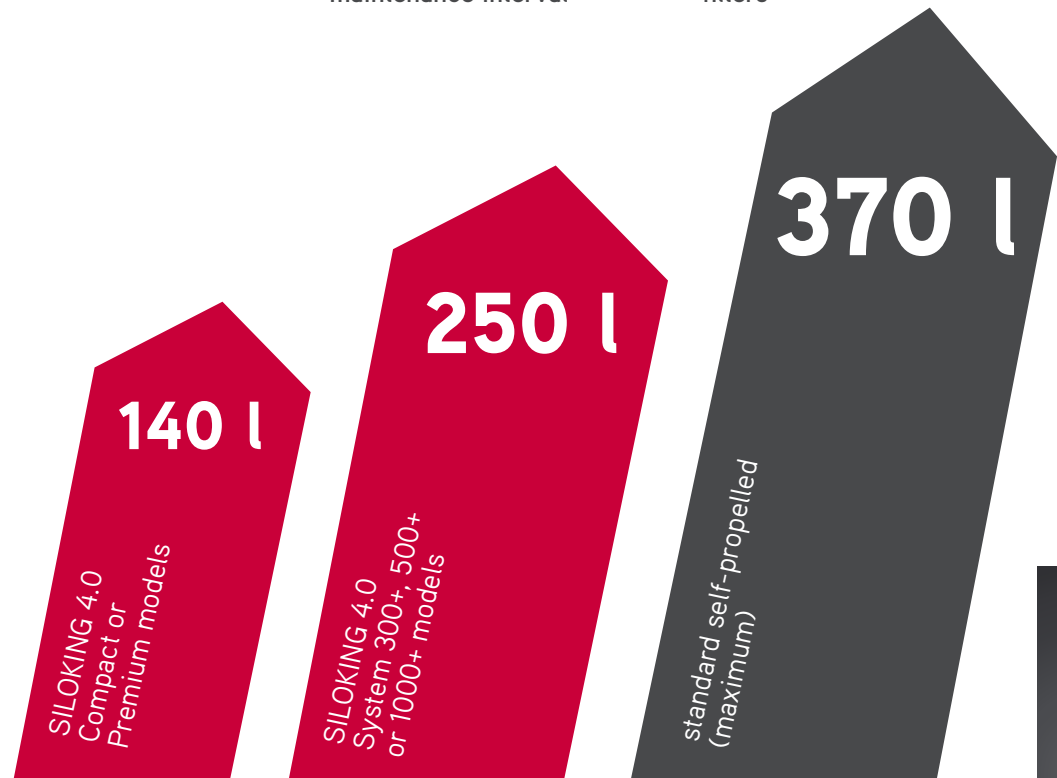

Best cooling performance for highest efficiency



A more than clean performance

The SILOKING **SelfLine 4.0** is equipped with a large single-surface radiator, which ensures highest cooling performance and therefore maximum efficiency. The modules for oil, water and charge air are arranged next to one another instead of behind one another and form a large-scale radiator unit. This inevitably leads to an excellent cooling performance.



Clean air in the most difficult conditions

Dust and fibres in the air, and this even in wet weather conditions: the challenges for the air filter system of self-propelled feed mixers are indeed unique and require sophisticated technology in terms of position and function!

Therefore, the air filter of the SILOKING **SelfLine** sucks in the less dust-laden air in the upper area of the machine, but is easily accessible from below for maintenance. Coarse dirt separator and dirt centrifuge in the upper area of the machine are cleaned automatically.

Radiator cleaning is standard

What is true for the air filter is also true for the radiator: high dust loads in wet weather conditions can quickly lead to sticking between the radiator fins. All SILOKING **SelfLine** models have always been equipped with an automatic reversing device for radiator cleaning! The large-surface radiator is regularly blown free with a strong air flow in the reverse direction.

Using the compressed air connection fitted as standard (from 20-km/h version), the complete machine can be cleaned easily.



System 300+ / 500+ / 1000+



The perfect environment for efficient working

Welcome to the driver's „workroom“! The challenge here is to keep concentration and motivation high through comfort and perfect ergonomics. For daily use, summer or winter, day or night, the cab of the SILOKING **SelfLine** is perfectly designed for comfort and functionality. The free view of the milling head and to the sides as well as the standard driver's seat with air suspension ensure the highest level of driving comfort. The multifunctional armrest also provides maximum legroom despite the compact design of the entire machine.

The forward-inclined windscreen reduces soiling and gives a comfortable feeling of space. The airflow for heating or air condition can be perfectly controlled and automatically adjusted via the terminal.

Professionally equipped and first-class workmanship, the cab offers the best noise insulation. And with the three-way adjustable steering column, working with the **SelfLine** is simply fun!





Everything on the SelfLine 4.0 is in series

- ▶ Seat with air suspension and ergonomically optimized multifunctional armrest
- ▶ Intuitive button and joystick control assignment
- ▶ Three-way adjustable steering column
- ▶ 3 large wipers
- ▶ Low noise level in the cab
- ▶ Large-space cab with excellent all-round visibility

The combination of carefully thought out innovations and improvements with a perfect sense of well-being results in up to 30 % higher daily performance.

Everything at a glance

The 10-inch display provides the driver with all the required information regarding operating conditions as well as loading and unloading functions. Control is carried out via push buttons or rotary wheel, which also works when wearing protective gloves. It is also possible to conveniently select the different modes (driving mode, loading mode, unloading mode, climate control mode, system mode) via the quick selection buttons in the armrest.

The terminal with functional keys for both the machine and the weighing system shows all the information about the SILOKING Data weighing system in the display along with the engine data. It is also possible to adapt ration settings and to set automatic functions of the mixing unit here.

By the way: mixing functions can be set or adjusted both via the Feeding Management Software included as standard and via the terminal.



10" display





Functions on demand

The multifunctional armrest mounted on the driver's seat achieves further increases in working efficiency. The button and joystick control assignments are intuitive and thereby extremely efficient.

For example, it is possible to save different engine speeds to save diesel, or to switch on mixing manually when leaving the machine, while complying with all safety regulations.

Easier work at the push of a button

One great example for the manner in which workload can be reduced to a minimum is the comfortable discharge management. Instead of requiring a plethora of manual inputs, a single push of a button is enough to initiate multiple hydraulic functions in an automated manner, such as the "extend discharge conveyor chain", "switch on discharge conveyor chain" and "open discharge door" functions. These combinations can be programmed individually and directly on the push buttons at any time.



Comfortable entry and immediate overview

The wide, wide-opening door and the low entry level to the cab provide additional safety and comfort. The cab of the SILOKING **SelfLine 4.0** is equipped with interior lighting as standard so that the driver can find his or her way around even in the dark.

Great all-round and upward visibility

Once the driver is seated, the unique cab design offers a fantastic all-round visibility. A roof panel with protective grille ensures good visibility upwards. For cleaning purposes, the hinged protective grille can be lifted without tools if it becomes very dirty. Speaking of cleaning windows: the effective wipers and water jets of the SILOKING **SelfLine 4.0** restore clear visibility as quickly as possible and are, of course, part of the standard equipment!



Excellent visibility, even in the dark

If light conditions are poor, the LED lighting strip ensures great visibility at close range. It is integrated into the roof grille and illuminates the main working area of the self-propelled feed mixer in an optimal way.

Cab functions that are easy to maintain

The high-performance air conditioning and heating system of the SILOKING **SelfLine 4.0** are housed in the cab roof where they are easily accessible. The filter systems for these two installations are also easily accessed from the ground for maintenance purposes. The electric fuse box is also outside the cab. Located next to the entry door, it can be reached without effort or obstruction.



SILOKING Data

SILOKING Data is the system specially developed by and for SILOKING for combining feeding program and machine control. It also includes free use of the web-based Feeding Management Software – for planning and documenting all rations and feeding processes.

With the **SelfLine**, everything is clearly presented in one terminal. Both machine data and the current feeding program can be seen at a glance!

Feeding Management Software included!

Keep control even without additional fees.



SILOKING Feeding Management

Advantages and functions

- ▶ Simple registration via the SILOKING Feeding Management website: siloking.com/en/digital/siloking-feeding-management
- ▶ Web-based application with personalized user access
- ▶ Access from any end device via Internet browser. Offers flexible access from the office, the barn, from home or from the holiday location etc.
- ▶ You always work with the latest software version
- ▶ Thanks to the web-based application there is no need for manual updates
- ▶ Mobile data transfer between weighing system and Feeding Management Software via SIM card (option)



Planning



- ▶ Easy creation and management of loading and unloading programs incl. adaption of dry matter contents and prices



Feeding



- ▶ Simple and intuitive data export and import via standard USB stick
- ▶ Detailed report indicating all loading and unloading processes



Control



- ▶ Representation:
 - Loading accuracy
 - Simple archiving
 - Analysis



Success



Keep an eye on costs!
Save money.



SILOKING Telematics

Farm Manager App for real-time monitoring/control of important individual farms' parameters regarding the SILOKING **SelfLine**



Always up-to-date, everywhere!

Especially in animal husbandry, it is important that the animals are supplied with the mixed feed ration 365 days a year. The SILOKING Telematics option allows the farm manager to have an overview of the current machine data, such as activity, consumption and temperature, at any place and at any time. With the error management, machine errors are reported immediately. Key feeding data is also sent regularly.

In the Farm Manager app dashboard, machine running times are broken down into times of activity and inactivity, and daily starting and ending times are displayed simply and clearly. A map function shows the location of the machine and can track its movement profile in real time.

SILOKING Assistenzsysteme





SILOKING DryScan®

SILOKING DryScan® enables kilogram-accurate loading of the feed mixer based on dry matter (DM) during the loading process, thanks to the combination of cutting-edge sensor technology and intelligent machine software. This method is significantly more precise than conventional calculations based on fresh matter.

All existing digital and assistance systems from SILOKING (e.g. weighing and software applications) are seamlessly integrated. This ensures easy operation, greater efficiency, and improved results throughout the entire feeding process.



SILOKING NIR System

NIR stands for near infrared spectroscopy and describes the process of using light sensors to measure the dry matter of the feed in real time and load it according to the current values. For this purpose, the NIR System is installed in the milling head of the SILOKING **SelfLine**.

The feed is released from the silage clamp by the milling head and passes through the dry matter scanner. The scanner evaluates the current dry matter content and transmits the data to the weighing system (Programmable weighing system DG8000-IC). The programmable weighing system calculates the target weight for each feed component compared with the planned ration in real time and shows it on the display. This ensures that the calculated ration is also loaded precisely.



SILOKING Straw chopper

Safe and precise cutting of dry and structure-rich feed components such as straw is easy with the SILOKING Straw chopper. The regular & short pieces of the feed components loaded are mixed into the feed ration quickly and homogeneously.

This makes it possible to use low-cost and available replacement feed components. The straw chopper is controlled comfortably by pushing a button on the joystick in the cab.

Available for System 300+, 500+ and 1000+ models.





3-point chassis



Unique – highly manoeuvrable

Its innovative 3-point chassis makes the SILOKING **SelfLine** 4.0 incredibly manoeuvrable and quick. The steering at the rear ensures efficient manoeuvring at the front, where the cab and milling head are located.

The robust square-bar frame is torsion-resistant thanks to its 3-point design and guarantees a long service life as well as exact weighing of the feed components. If the feed table is particularly narrow, the feed can also be discharged on both sides at the same time using 2 discharge doors – guaranteed without rolling over the feed.

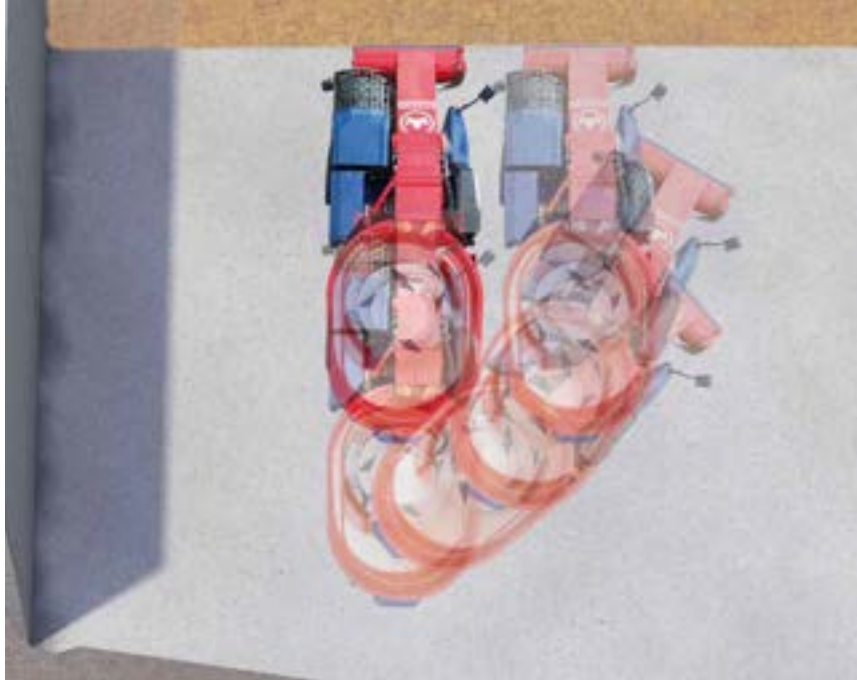

Ideally, the feed should be extracted over the entire width of the silo every day! The SILOKING 3-point chassis is perfectly designed for this function.

SILOKING steering – simply – ingenious – flexibility

The unique steering unit at the rear includes, in addition to the enormous manoeuvrability, the possibility to deposit the feed simultaneously on both sides behind the machine in narrow barn passages. The wheels of the narrow axle do not roll over the feed. The impressively simple steering system is low-maintenance, wear-resistant and still offers good driving stability even at 40 km/h.

Full traction on one axle

The chassis of the SILOKING **SelfLine** 4.0 benefits from a highly intelligent concept. 70 % of the total weight are on the front drive axle of the self-propelled. This offers multiple advantages, such as improved traction even if the mixing hopper is empty and in snow.

Large wheels and a low centre of gravity also give the machine good stability, even with a full load.

Perfect driving comfort

The SILOKING **SelfLine** 4.0 not only uses its outstanding characteristics on the farm, but also on the road. The machine is available in 4 speed versions (15 / 20 / 25 / 40 km/h). From the 20-km/h version upwards, the air suspension at the front and rear guarantees best driving comfort.

The automatic level control from the truck technology adjusts the suspension with different loads and accordingly ensures safety and driving stability of the chassis. For longer travels, SILOKING optionally offers an additional shock-absorbing system for the milling arm to prevent vibrations.



Independent wheel suspension for difficult roads

For difficult road conditions, the **SelfLine Compact** and the **SelfLine Premium** can be equipped with independent wheel suspension as an option – it is standard for **SelfLine Premium 2215-22**. The professional construction with parallelogram, shock absorbers and large wheels absorbs vibrations and shocks particularly well and, in contrast to swing axles, is very wear-resistant.



For family farms and individual feeding
of performance groups



SILOKING SelfLine 4.0 Compact 1612

Models with low height with 13 m³ and 16 m³ mixing capacity

The optimal machine both for conventional family farms and for large farms with various performance groups, or with narrow and low-height barn entrances! As the name Compact suggests, the models are only 2.65 m high and also fit through low barn buildings. On machines with air suspension, the chassis lowering system makes it possible to reduce the total height even to 2.59 m at the push of a button for driving through the barn.

Both models are equipped with the powerful and economical 105 kW (143 hp) Volvo 4-cylinder turbo diesel engine. There is an optional Power pack with 129 kW (175 hp) or 160 kW (218 hp).



Perfect view of the milling head in any working position.



Compact design and two-sided discharge without running over the feed.



Low entry and clearly arranged comfort cab.



High capacity and big
loading heights



SILOKING SelfLine 4.0 Premium 2215

Models with big loading height and more capacity, with 15 m³, 19 m³ and 22 m³

Due to the high capacity, these models are the ideal solution for large farms and farms with big performance groups.

With their long milling arm, all Premium models can load the feed from heights up to 5 m. The standard drive on these models is a Volvo 4-cylinder turbo diesel engine with 129 kW (175 hp) and with 160 kW (218 hp) as option. In addition, the 3-point chassis provides the machine with a minimal turning radius.





Perfect solutions for feed discharge



The retractable discharge conveyor chain can work in every position and produces a regular feed discharge.



An optional PVC discharge conveyor belt is available as an alternative to the discharge conveyor chain.



Simultaneous two-sided feed discharge, e. g. with particularly narrow feed tables, is also possible. The narrow steering unit at the rear ensures that even with big feed amounts, the feed is not run over.



Flexible discharge and regular feed deposit thanks to adapted technology

A whole range of (optional) SILOKING discharge conveyors is available to adapt feed discharge to any requirements in the barn.



SILOKING Bedding belt

The SILOKING Bedding belt is the perfect combination for loose and wide feed discharge and large-distance bedding of cubicles with one machine only.

The angle and speed are adjusted hydraulically via the multifunctional armrest.

Discharge door at front right.



The foldable discharge conveyor chain is perfect for feeding into high troughs.



The discharge conveyors are controlled simply by pushing a button from the driver's cab.





2- or 3-axle chassis

Heavy-duty axles for heavy loads

The axles of our System 300+, 500+ and 1000+ models with their powerful drive coming from the building and transport industries also convince when facing the daily challenges on the farm and on the road.

Thanks to the chassis with air suspension and automatic level control the machine offers smooth running and high comfort in all conditions, while offering maximum reliability.



High ground clearance and discharge height for System 300+ / 500+ / 1000+

The chassis of the System 300+ / 500+ / 1000+ is designed for use on large farms and farms with difficult ground conditions. The machines are equipped with 4-wheel steering as standard and have large tyres with excellent flexing properties. Due to the machine's height, the standard feed discharge is already ca. 1 metre high and with additional conveyor belts, feeding into even very high troughs is extremely simple and clear.

For use on several farms involving fast road travel, the System 500+ model range is equipped with external air-operated drum brakes as standard. This ensures maximum brake force and low wear, even in the case of long distances. The System 500+ is also available with optional 4-wheel drive to meet extremely difficult challenges when driving over land.



4-wheel drive for System 1000+

When used on large farms, logistics play a major role, even when driving on the farm premises. For big machines with maximum payloads, it is recommended to distribute the load evenly over the entire chassis to reduce ground pressure. The **SelfLine** System 1000+ is equipped with a 3-axle chassis, which is driven as standard and constantly via the 1st and 2nd axles. In case of slippage on one axle, the drive is automatically transferred to the better gripping axle.

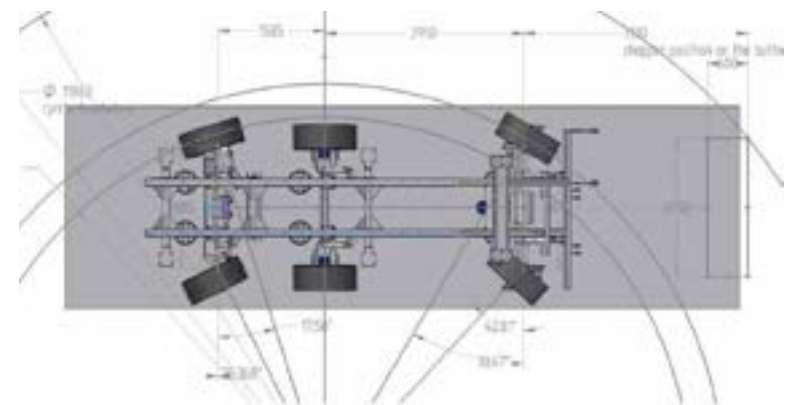

The 4-wheel steering at the front and rear axles gives the machine exceptionally good manoeuvrability. For more safety, steering at higher speeds is carried out only via the front axle. The front axle is also equipped with an external air-operated drum brake with particularly long durability. 40 km/h and air suspension are standard equipment.

Typical farm conditions with high
mixing capacity



SILOKING SelfLine 4.0 System 300+ 2519

The high-capacity farm machine with 19 m³, 22 m³, 25 m³ and 27 m³

The **SelfLine** System 300+ is focused on reliability and maximum load capacity. The robust chassis, together with high mixing capacity, ensures long service life and high efficiency even with particularly heavyweight rations.

The chassis with air suspension, 4-wheel steering and large tyres offers not only driving comfort at 25 km/h but also high ground clearance with excellent traction. This means that, in addition to many other discharge options, individual feed deposit into high troughs is also no problem.

With a feed loading height of up to 5.3 m, the high-performance milling head is also perfect for high silos on large farms.

Powerful drive used intelligently

Cost reduction in two senses is realised by combining the high-torque 160 kW (218 hp) Volvo engine with the known 1,000-hour maintenance interval and low diesel consumption. Thanks to the perfect matching of the axial piston pumps for the milling head, traction drive and mixing unit, this power pack achieves its economic efficiency with a high degree of efficiency.

Highly manoeuvrable and compact

Due to the standard 4-wheel steering, the self-propelled drives quickly from the silo to the feed table and manages confined and angled farm conditions without any problems.

The air suspension at the front and rear add to the machine's high driving comfort. With total heights from 2.9 m, this system is kept relatively low, whereby the chassis lowering system makes it possible to reduce the total height to 2.84 m at the push of a button from the driver's seat for driving through the barn.



STRONG – on the road and in
difficult conditions on the farm



SILOKING SelfLine 4.0 System 500+ 2519

The allrounder for farm and road travel with 19 m³, 22 m³, 25 m³ and 27 m³

The System 500+ is designed for farms with 500 and more animals, for dairy farms with several locations, feeding communities or agricultural contractors.

Excellent driving behaviour in any conditions

The models are equipped with a 40-km/h speed version as standard. For quick road travel, even 50 km/h are available for the System 500+ as option. The wear-resistant drum brakes mounted outside reduce running resistance as well as diesel consumption while offering a high level of driving safety.

The machine convinces with its powerful 185 kW (252 hp) 6-cylinder drive engine offering quick feed loading and homogeneous mixing.

4x4 drive

The machine's enormous manoeuvrability comes as an advantage especially in confined and angled farm conditions. 4-wheel steering and a turning radius from 8.5 m make it possible to manoeuvre the self-propelled in an excellent way.

When driving fast on roads, the machine switches to front-wheel steering. For use on unpaved roads as well as in terrain and on particularly difficult slopes, the machine can be equipped with optional 4-wheel drive. In addition to the standard large tyres with excellent flexing properties, SILOKING also offers various tyre profiles as required.



Developed for farms with 1,000
and more cows



SILOKING SelfLine 4.0 System 1000+ 3225

Highly manoeuvrable XXL self-propelled for large farms and use on several farms, with 25 m³, 27 m³, 29 m³ and 32 m³

The development of the System 1000+ focused on maximum efficiency and best mixing results!

On large farms, long transport distances with heavy loads are inevitable even for simple farm travel. Meanwhile, the time required and diesel consumption for loading and mixing play a major role in economic efficiency.

The key to the economic efficiency of the System 1000+ lies in the combination of all machine features:

With a turning radius of only 11 m even on the largest model with 32 m³, the vehicle is enormously manoeuvrable and quick to manoeuvre for loading in the silo! The conically shaped mixing hopper, for its part, ensures that the mixing unit has a very low power requirement and can therefore remain switched on even when the milling head is working at full load. This shortens mixing times considerably!

Power package for efficiency

The milling head and the loading conveyor belt (just like the traction and mixing drive) each have their own hydrostatic drive, because the long loading belt also has to transport large feed quantities in the shortest possible time! With the milling arm boost, the maximum loading height of 5.5 m is quickly reached again when the milling head is raised. The Volvo 6-cylinder turbo diesel engine is precisely matched to the 4 axial piston pumps, resulting in excellent efficiency!

It's the overall concept that makes it!

It is the overall concept with 4-wheel steering plus 4-wheel drive and a power-saving mixing drive plus additional milling drive that brings unbeatable efficiency to the entire machine. This unique „system“ saves time and fuel, very decisive factors for economic efficiency.





Perfect solutions for feed discharge

46

SILOKING



With 2 discharge doors at the rear, the feed can also be deposited on both sides in one operation.

For feeding into high troughs, the retractable discharge conveyor belt is inclined upwards.



The cross conveyor belt at the rear of the machine enables the feed to be deposited along the entire length of the dead-end feed table.



The cross conveyor belt at the rear of the machine can also be equipped with hydraulic side sliding.



Regular feed deposit – reliable function

All the solutions focus on regular feed deposit, simple control and reliable function.



SILOKING Solutions for every farm

SILOKING offers a wide range of different conveyor belts and discharge openings from serial production for regular feed deposit, even into high troughs. This provides flexibility, operational reliability and quick solutions in service cases.

The foldable discharge conveyor chain allows for regular feed deposit even into very high troughs.

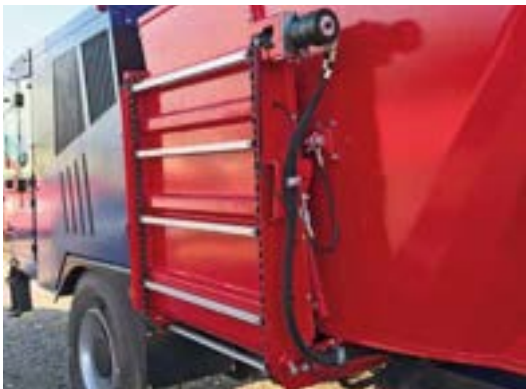

Heavy-duty discharge doors with extra large opening are particularly suitable for long-fibred feed and for feed deposit right next to the machine.



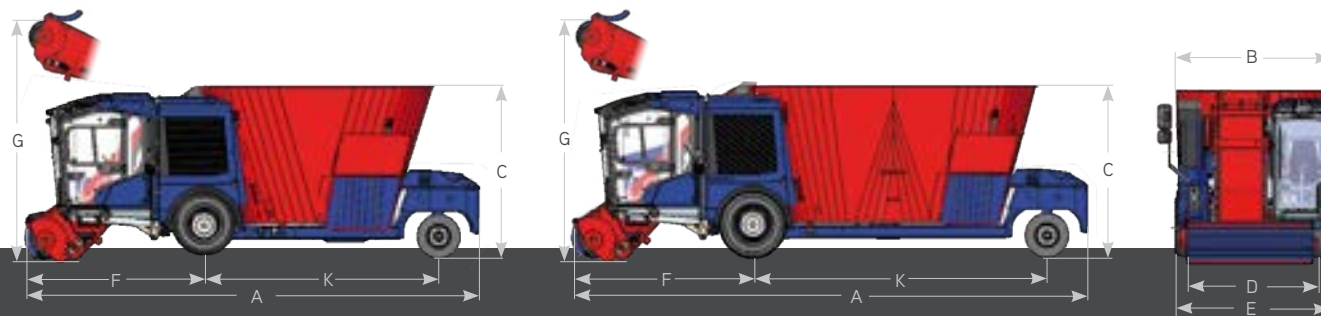

Technical specifications

Model		Compact 1612-13	Compact 1612-16
A Length	mm	7.710	8.390
F Distance milling head - axle	mm	2.950	2.950
K Distance front axle - rear axle	mm	3.840	4.700
B Width	mm	2.550	2.550
C Height	mm	2.650	2.650
D Track width	mm	1.920	1.920
E Outer width of wheels	mm	2.300	2.300
Outer turning radius	mm	5.500	7.000
Turbo augers		1	2
Auger windings		2,5	2,5
Adjustable XS knives		7	14
Capacity	m ³	13	16
G Loading height	m	4,2	4,2
Empty weight of basic machine	kg	11.320	12.270
Engine	kW / hp	105 / 143 Volvo	105 / 143 Volvo

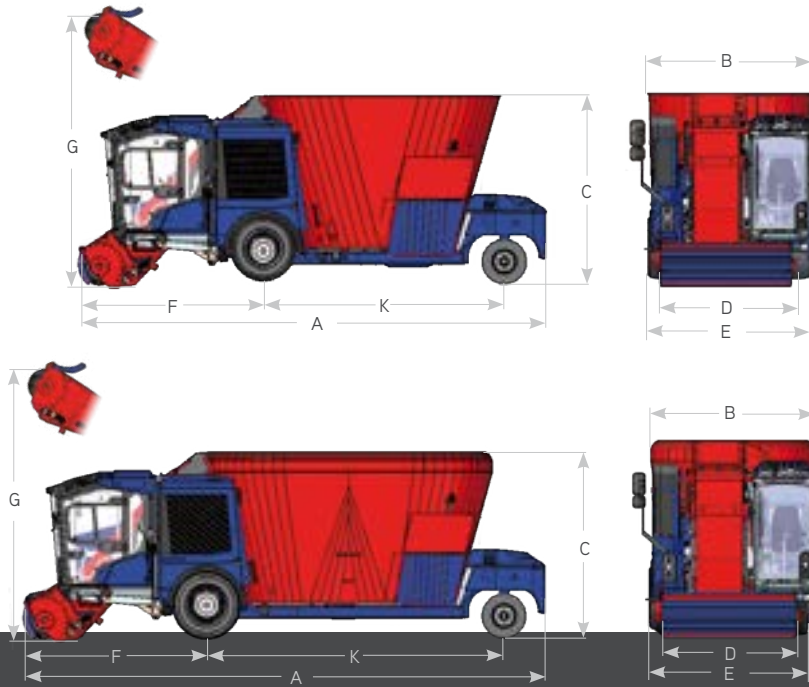

Technical specifications

Model		Premium 2215-15	Premium 2215-19	Premium 2215-22
A Length	mm	7.710	8.610	8.840
F Distance milling head - axle	mm	3.100	3.100	3.100
K Distance front axle - rear axle	mm	3.850	4.700	5.100
B Width	mm	2.550	2.550	2.550
C Height	mm	2.990	2.990	3.060
D Track width	mm	1.920	1.920	1.920
E Outer width of wheels	mm	2.300	2.440	2.550
Outer turning radius	mm	5.500	7.000	8.700
Turbo augers		1	2	2
Auger windings		3	3	3,5
Adjustable XS knives		8	16	18
Capacity	m ³	15	19	22
G Loading height	m	5,0	5,0	5,0
Empty weight of basic machine	kg	11.820	13.220	14.170
Engine	kW / hp	129 / 175 Volvo	129 / 175 Volvo	129 / 175 Volvo

Turning radius

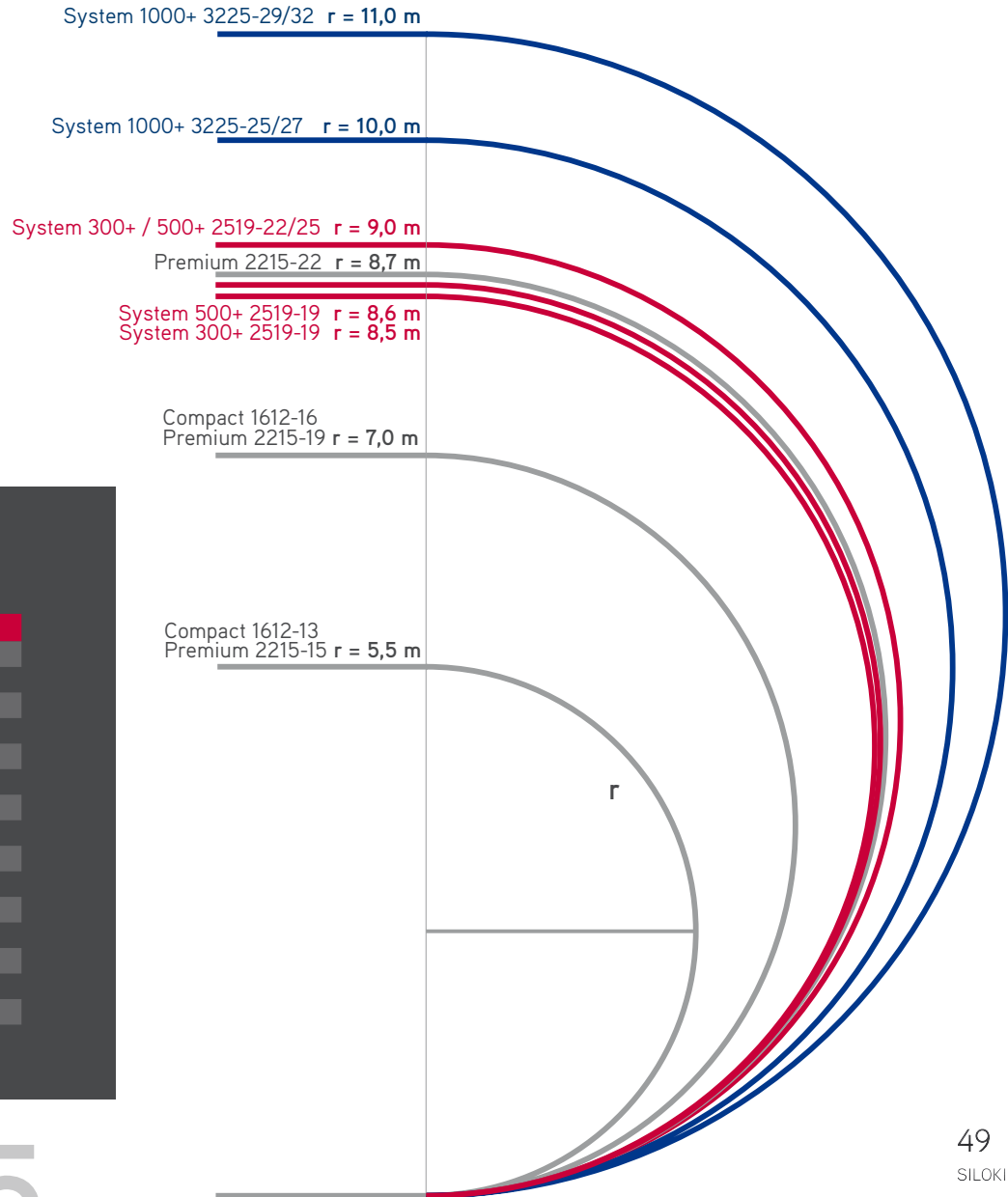

Premium 2215



Technical specifications

Model		System 300+ 2519-19	System 300+ 2519-22	System 300+ 2519-25	System 300+ 2519-27
A Length	mm	8.930	9.460	9.460	9.460
J Length (with cross conveyor belt)	mm	9.350	9.880	9.880	9.880
F Distance milling head - axle	mm	2.950	3.450	3.300	3.300
K Distance front axle - rear axle	mm	3.800	4.000	4.000	4.000
B Width	mm	2.540	2.540	2.540	2.680
C Height	mm	2.950	3.330	3.480	3.530
Tyres at front		385/65 R22.5	425/65 R22.5	425/65 R22.5	425/65 R22.5
Tyres at rear		455/40 R22.5	435/50 R22.5	435/50 R22.5	435/50 R22.5
D Track width	mm	2.180	2.180	2.180	2.180
E Outer width of wheels	mm	2.500	2.500	2.500	2.500
Outer turning radius (4-wheel steering)	mm	8.500	9.000	9.000	9.000
Outer turning radius (2-wheel steering)	mm	11.050	11.900	11.900	11.900
Turbo augers		2	2	2	2
Auger windings		2,5	3	3,5	3,5
Adjustable XS knives		14	16	18	18
Capacity	m ³	19	22	25	27
H Discharge height (discharge door)	mm	1.010	1.060	1.060	1.060
I Discharge height (cross conveyor belt)	mm	920	970	970	970
cross conveyor belt with hydraulic sliding to both sides (300 mm per side)					
G Loading height	m	4,8	5,2	5,3	5,3
Empty weight of basic machine	kg	15.900	16.200	16.400	16.600
max. total weight (technically) 25 km/h	kg	25.900	25.900	25.900	25.900
Engine	kW / hp	160 / 218 Volvo	160 / 218 Volvo	160 / 218 Volvo	160 / 218 Volvo

* The total weight may vary due to country-specific regulations for road traffic.

Technical specifications

Model		System 500+ 2519-19	System 500+ 2519-22	System 500+ 2519-25	System 500+ 2519-27
A Length	mm	8.930	9.460	9.460	9.460
J Length (with cross conveyor belt)	mm	9.350	9.880	9.880	9.880
F Distance milling head - axle	mm	2.950	3.450	3.300	3.300
K Distance front axle - rear axle	mm	3.800	4.000	4.000	4.000
B Width	mm	2.540	2.540	2.540	2.680
C Height	mm	2.970	3.350	3.500	3.550
Tyres at front		445/65 R22.5	445/65 R22.5	445/65 R22.5	445/65 R22.5
Tyres at rear		435/50 R22.5	435/50 R22.5	435/50 R22.5	435/50 R22.5
D Track width	mm	2.050	2.050	2.050	2.050
E Outer width of wheels	mm	2.490	2.490	2.490	2.490
Outer turning radius (4-wheel steering)	mm	8.600	9.000	9.000	9.000
Outer turning radius (2-wheel steering)	mm	11.050	11.900	11.900	11.900
Turbo augers		2	2	2	2
Auger windings		2,5	3	3,5	3,5
Adjustable XS knives		14	16	18	18
Capacity	m ³	19	22	25	27
H Discharge height (discharge door)	mm	1.080	1.080	1.080	1.080
I Discharge height (cross conveyor belt)	mm	990	990	990	990
cross conveyor belt with hydraulic sliding to both sides (300 mm per side)					
G Loading height	m	4,8	5,2	5,3	5,3
Empty weight of basic machine	kg	15.800	16.100	16.350	16.550
max. total weight (technically) 25 km/h	kg	25.900	25.900	25.900	25.900
Engine	kW / hp	185 / 252 Volvo	185 / 252 Volvo	185 / 252 Volvo	185 / 252 Volvo

* The total weight may vary due to country-specific regulations for road traffic.

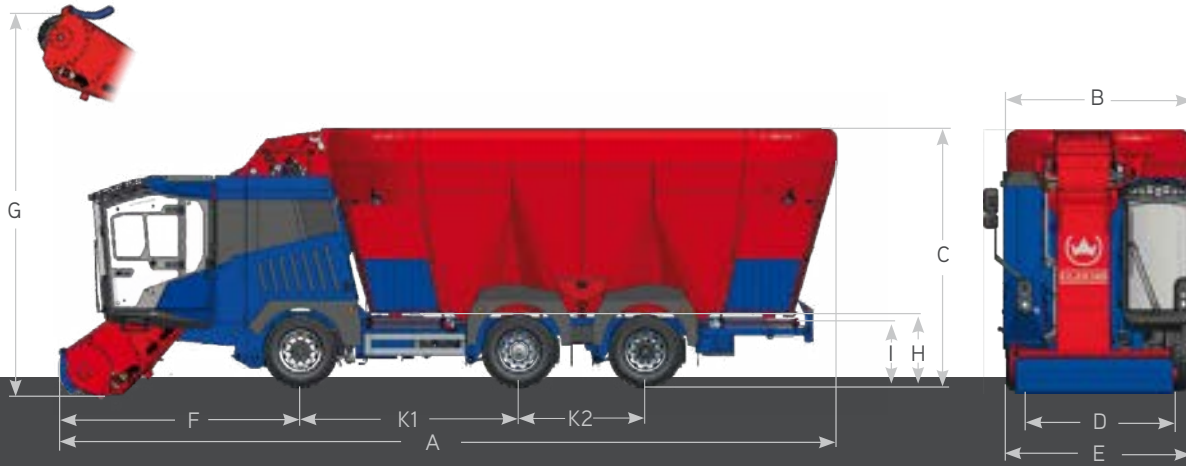

Technical specifications

Model		System 1000+ 3225-25	System 1000+ 3225-27	System 1000+ 3225-29	System 1000+ 3225-32
A Length	mm	9.460	9.460	10.600	10.600
Length (with cross conveyor belt)	mm	9.880	9.880	11.020	11.020
F Distance milling head - axle	mm	3.300	3.300	3.300	3.300
K1 Distance front axle - central axle	mm	2.620	2.620	2.940	2.940
K2 Distance central axle - rear axle	mm	1.380	1.380	1.700	1.700
B Width	mm	2.550	2.710	2.550	2.550
C Height	mm	3.530	3.580	3.400	3.500
Tyres		385/55 R22.5	385/55 R22.5	385/55 R22.5	385/55 R22.5
D Track width	mm	2.060	2.060	2.060	2.060
E Outer width of wheels	mm	2.450	2.450	2.450	2.450
Outer turning radius	mm	10.000	10.000	11.000	11.000
Turbo augers		2	2	3	3
Auger windings		3,5	3,5	3	3,5
Adjustable XS knives		18	18	24	27
Capacity	m ³	25	27	29	32
H Discharge height (discharge door)	mm	1.140	1.140	1.050	1.050
I Discharge height (cross conveyor belt)	mm	1.060	1.060	970	970
cross conveyor belt with hydraulic sliding to both sides (300 mm per side)					
G Loading height	m	5,5	5,5	5,3	5,5
Empty weight of basic machine	kg	17.250	17.300	17.950	18.250
max. total weight (technically) 25 km/h	kg	29.800	29.800	29.800	29.800
Engine	kW / hp	210 / 286 Volvo	210 / 286 Volvo	210 / 286 Volvo	210 / 286 Volvo

* The total weight may vary due to country-specific regulations for road traffic.

System 1000+



Top partnership for maximum success



SILOKING Service and spare parts

- ▶ 24-h availability / 7-day week
- ▶ Area-wide and quick service



Service Partner

- ▶ Audited by SILOKING
- ▶ Trained know-how
- ▶ High parts availability on site

SILOKING

www.siloking.com



Your SILOKING Partner

SILOKING Mayer Maschinenbau GmbH
Kehlsteinstraße 4 | 84529 Tittmoning | Germany
Phone +49 8683 8984-0 | E-Mail info@siloking.com



Illustrations may include special equipment, subject to errors and modifications.